

Rewin 瑞辉

公差/General tolerances(mm)

0	>3	>6	>10	>18	>30	>50	>120	>180	>250	>315	>400	>500
~3	~6	~10	~18	~30	~50	~80	~180	~250	~315	~400	~500	>500
±0.12	±0.18	±0.22	±0.26	±0.31	±0.37	±0.57	±0.80	±0.93	±1.05	±1.60	±2.20	±2.50

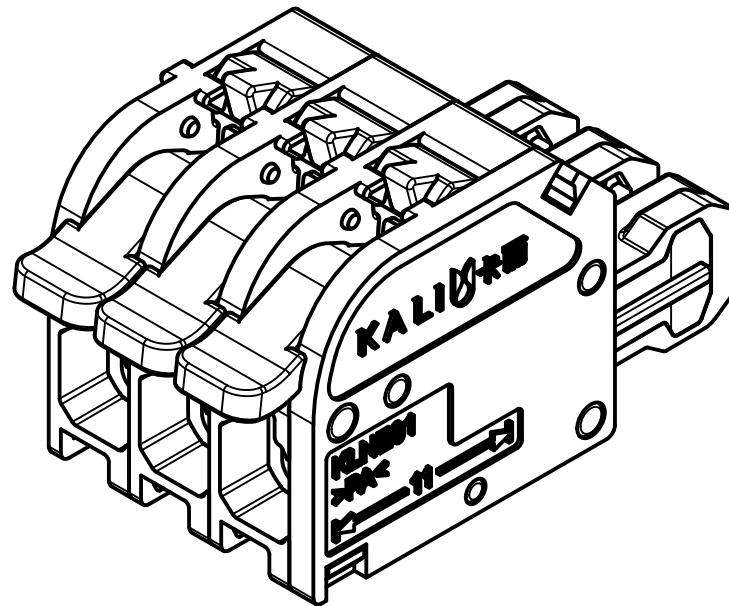
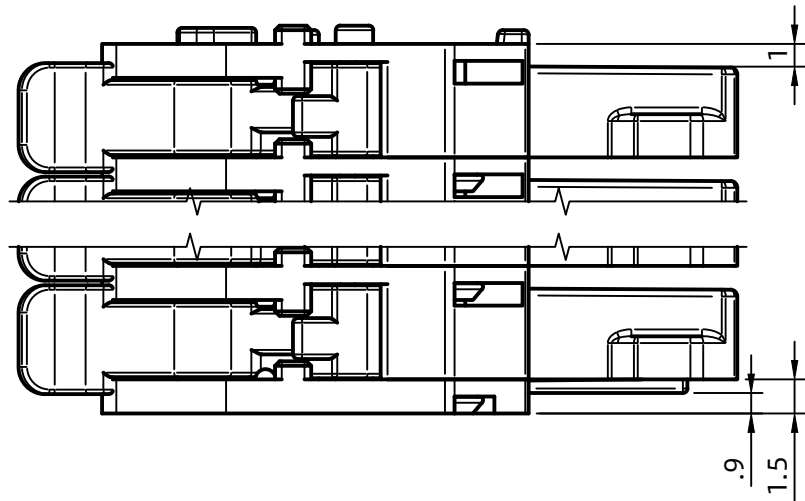
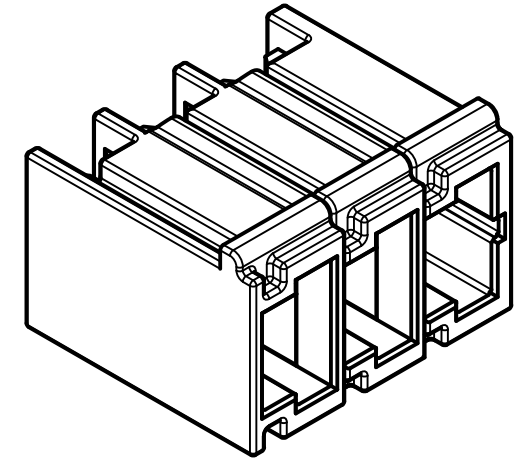
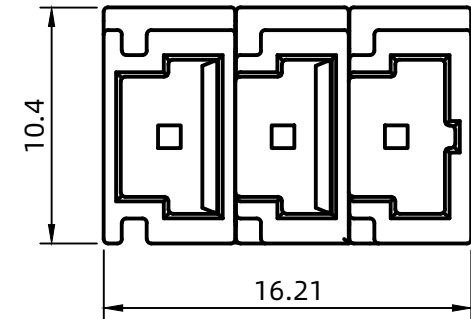
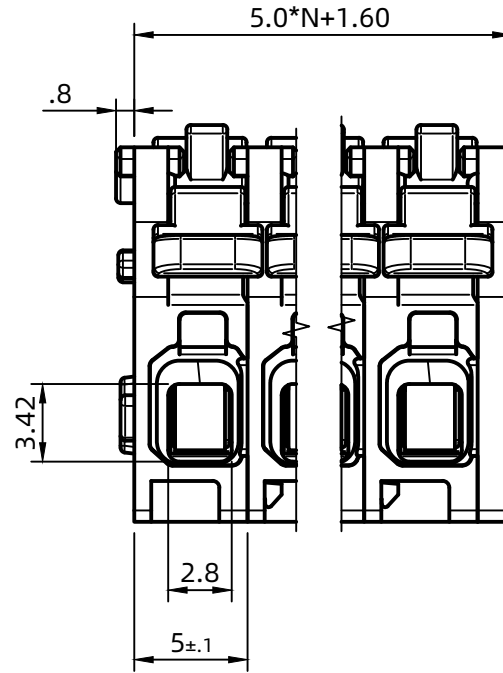
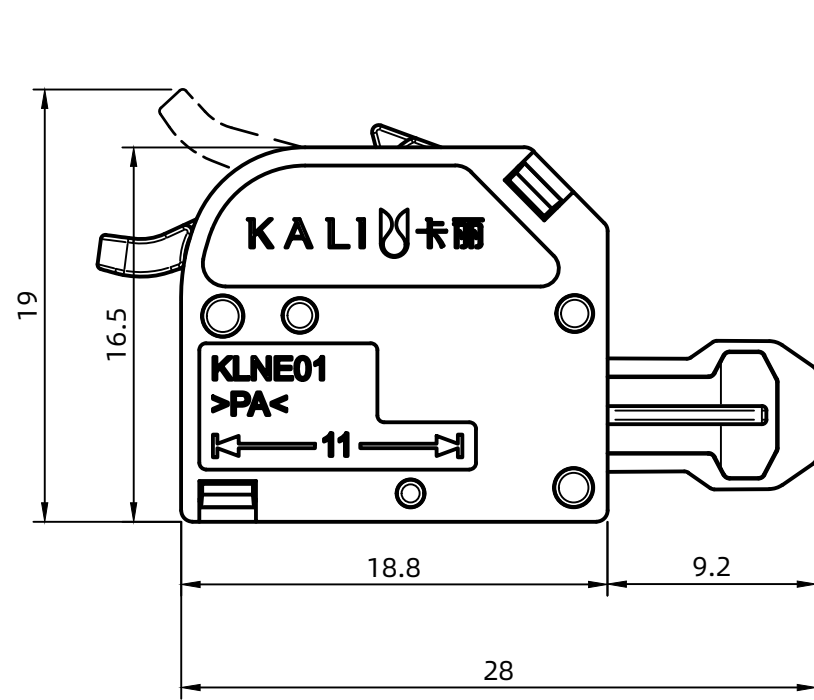

UL 标准/UL Standard	UL1059		
Use Group	B	D	
额定电压/电流/Rated Voltage(V)/Current(A)	300V/16A	300V/16A	
IEC 标准/IEC Standard	60664 & 61984		
过压类别/Overvoltage Category/污染等级/Pollution Degree	III/3	III/2	II/2
额定电压/电流/Rated Voltage(V)/Current(A)	/	320V/18A	/
额定脉冲电压 (kV) /Rate Impulse Voltage(kV)	/	4kV	/
线径范围 (硬线&软线) /Wire Range(rigid&flexible)(mm ² /AWG)	0.5...2.5 / 20...12		
间距/Pitch(mm)/线数范围/Poles	5.0/N=2~12P		
剥线长度/Stripping length(mm)	10-12		
使用温度范围Operating temperature(°C)	-40~+85		
符合RoHS环保要求/Conform to RoHS	YES		

Transfer or duplication of this document as well as the utilization or communication of its contents are prohibited unless explicit authorization is granted. Violations will be liable for compensation. All rights reserved for patent, utility model or designs registrations.

REV					ECN	DESCRIPTION	DRFT	DATE	MAT NO.:		浙江瑞辉电气有限公司 ZHEJIANG REWIN ELECTRIC CO.,LTD		
V3					19mm	Xuhy	25.12.15	APPD:	NAME:				
V2					Stripping length	Xuhy	25.11.13	CHKD:	KLNE1-P-5.0-V-N-GY				
V1					UL/IEC/NAME DATE	Nirw	25.3.4	DRFT:Nirw 24.6.19	DRAWING NO.: 10000001			REV	V3
REV	ECN	DESCRIPTION	DRFT	DATE	SIZE:A3	mm	TYPR:CUSTOMER DRAWING	SCALE:3:1	SHEET	1/1			